

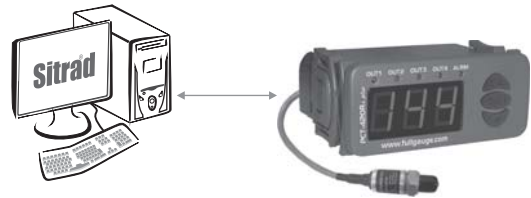

PCT-420R^{i plus}

FOUR-STEP PRESSURE CONTROLLER

Ver.01



PTC420V01-02F-11086

1. DESCRIPTION

The **PCT-420R^{i plus}** is a digital pressure controller intended to be used in systems that need pressurization or depressurization control. Through the advanced function menu the user can configure any of the 4 outputs for pressure control. The last 2 outputs can also be configured as an alarm or cyclic timer. When used together with the SB-48 pressure transducer, the **PCT-420R^{i plus}** is capable to measure pressure in the following ranges: -14 to 100 psi; -1.0 to 6.9 bar; -14 to 500 psi and 1.0 to 34.4 bar.

The outputs configured for pressure control (pressurization or depressurization) have an internal timer for activating the service alarm and operating the automatic rotative output actuation.

The **PCT-420R^{i plus}** also features communication with the application software SITRAD[®]. The device is easy to install and can be operated remotely, via web.

2. APPLICATION

- Water pumps
- Refrigeration systems
- Protection systems against fire
- Etc.

3. TECHNICAL SPECIFICATIONS

- Power supply: 12Vdc from the external power supply included (127/220VAC ±10% 50/60Hz)
- Pressão de controle: 0 to 100 psi / 0 to 6.9 bar (using the transducer of 100 psi)
0 to 500 psi / 0 to 34.4 bar (using the transducer of 500 psi)
- Accuracy: 1 psi / 0.1 bar
- Max. current in each output: 5(3) A / 250Vac 1/8HP
- Dimensions: 71 x 28 x 71mm
- Controller operation temperature: 0° to 50°C(32° to 122°F)
- Transducer operation temperature: -40° to 125°C(-40° to 257°F)
- Operation humidity: 10 to 90% RH (without condensation)
- Control outputs: OUT1 - First stage output
OUT2 - Second stage output
OUT3 - Third stage output
OUT4 - Fourth stage output
ALRM - Alarm indication Led

4. CONFIGURATION

4.1 - Setpoints configuration

- Press the **SET** key for 2 seconds to display **SEL**, and then release the key. **SP1** and the temperature adjusted for the first stage are displayed. Use **▼** and **▲** keys to change the value and then press **SET**. Repeat the procedure to adjust **SP2** (2nd stage), **SP3** (3rd stage) and **SP4** (4th stage).

Note: if the 3rd or 4th stages are configured for cyclic timer or alarm, the setpoint adjustment for the corresponding stage will be suppressed.

4.2 - To enter the function menu

Press **▼** and **▲** simultaneously for 2 seconds to display **Fun** and release the keys. When **F01** is displayed, press **SET** (shortly) and enter the code '123' using **▼** and **▲** keys. Press **SET** to confirm. Use **▼** and **▲** to access other functions and perform the same procedure to configure them. To exit the menu and return to the normal operation hold the **SET** key pressed until **---** is displayed.

4.3 - Parameters table

Fun	Description	LOW PRESSURE (0 - 100psi / 0 6.9 bar)				HIGH PRESSURE (0 - 500psi / 0 34.4 bar)			
		Min	Max	Unit	Default	Min	Max	Unit	Default
F01	Access code	-99	999	-	0	-99	999	-	0
F02	Offset indication	-20/-1.4	20/1.4	psi/bar	0/0.0	-50/-3.4	50/3.4	psi/bar	0/0.0
F03	Stage 1 operation mode	0	1	-	0	0	1	-	0
F04	Minimum setpoint allowed for stage 1	0/0.0	100/6.9	psi/bar	0.0	0/0.0	500/34.4	psi/bar	0.0
F05	Maximum setpoint allowed for stage 1	0/0.0	100/6.9	psi/bar	100/6.9	0/0.0	500/34.4	psi/bar	500/34.4
F06	Hysteresis for controlling stage 1	1/0.1	15/1.0	psi/bar	1/0.1	1/0.1	75/5.0	psi/bar	5/0.4
F07	Stage 2 operation mode	0	1	-	0	0	1	-	0
F08	Minimum setpoint allowed for stage 2	0/0.0	100/6.9	psi/bar	0/0.0	0/0.0	500/34.4	psi/bar	0/0.0
F09	Maximum setpoint allowed for stage 2	0/0.0	100/6.9	psi/bar	100/6.9	0/0.0	500/34.4	psi/bar	500/34.4
F10	Hysteresis for controlling stage 2	1/0.1	15/1.0	psi/bar	1/0.1	1/0.1	75/5.0	psi/bar	5/0.4
F11	Stage 3 operation mode	0	6	-	0	0	6	-	0
F12	Minimum setpoint allowed for stage 3	0/0.0	100/6.9	psi/bar	0/0.0	0/0.0	500/34.4	psi/bar	0/0.0
F13	Maximum setpoint allowed for stage 3	0/0.0	100/6.9	psi/bar	100/6.9	0/0.0	500/34.4	psi/bar	500/34.4
F14	Hysteresis for controlling stage 3	1/0.1	15/1.0	psi/bar	1/0.1	1/0.1	75/5.0	psi/bar	5/0.4
F15	Stage 4 operation mode	0	6	-	0	0	6	-	0

F16	Minimum setpoint allowed for stage 4	0/0.0	100/6.9	psi/bar	0/0.0	0/0.0	500/34.4	psi/bar	0/0.0
F17	Maximum setpoint allowed for stage 4	0/0.0	100/6.9	psi/bar	100/6.9	0/0.0	500/34.4	psi/bar	500/34.4
F18	Hysteresis for controlling stage 4	1/0.1	15/1.0	psi/bar	1/0.1	1/0.1	75/5.0	psi/bar	5/0.4
F19	Low pressure alarm	0/0.0	100/6.9	psi/bar	0/0.0	0/0.0	500/34.4	psi/bar	0/0.0
F20	High pressure alarm	0/0.0	100/6.9	psi/bar	100/6.9	0/0.0	500/34.4	psi/bar	500/34.4
F21	Stage action when sensor error occurs	0	15	-	0	0	15	-	0
F22	Alarm time ON	0	999	sec.	1	0	999	sec.	1
F23	Alarm time OFF	0	999	sec.	1	0	999	sec.	1
F24	Alarm guard time OFF	0	999	min.	0	0	999	min.	0
F25	Cyclic timer time ON	1	999	sec./min	1	1	999	sec./min	1
F26	Cyclic timer time OFF	1	999	sec./min	1	1	999	sec./min	1
F27	Cyclic timer time unit	0 - sec.	1 - min.	-	0 - sec.	0 - sec.	1 - min.	-	0 - sec.
F28	Cyclic timer guard time	0	999	min.	0	0	999	min.	0
F29	Controller OFF guard time	0	999	min.	0	0	999	min.	0
F30	Minimum stage time ON	0	999	sec.	0	0	999	sec.	0
F31	Minimum stage time OFF	0	999	sec.	0	0	999	sec.	0
F32	Minimum time between actuation of 2 different stages	0	999	sec.	0	0	999	sec.	0

F33	Actuation sequence	0	3	-	0	0	3	-	0
F34	Relative output actuation	0 - no	1 - yes	-	0 - no	0 - no	1 - yes	-	0 - no
F35	Max. operation time between services for stage 1	0	999	x10h	999	0	999	x10h	999
F36	Max. operation time between services for stage 2	0	999	x10h	999	0	999	x10h	999
F37	Max. operation time between services for stage 3	0	999	x10h	999	0	999	x10h	999
F38	Max. operation time between services for stage 4	0	999	x10h	999	0	999	x10h	999
F39	Device address in the RS-485 network (serial communication)	1	247	-	1	1	247	-	1

4.4 - Parameters description

F01 Access code (123)

The code is needed when you want to change the parameter settings. If you just want to view the parameters, you don't need to input the access code.

F02 Offset indication

Allows an eventual compensation for the changes in the pressure readings caused when the sensor is replaced.

F03 Stage 1 operation mode

Depressurization: the stage is turned ON when the pressure is equal to or higher than (SP1+F06) and is turned OFF when the pressure is lower than SP1.

Pressurization: the stage is turned ON when the pressure is equal to or lower than (SP1-F06) and turned OFF when the pressure is bigger than SP1.

F04 Minimum setpoint allowed for stage 1

Lower limit created to avoid that extremely low pressures be configured for setpoint 1.

F05 Maximum setpoint allowed for stage 1

Upper limit created to avoid that extremely high pressures be configured for setpoint 1.

F06 Hysteresis for controlling stage 1

This is the difference between the pressures needed to turn stage 1 ON and OFF

F07 Stage 2 operation mode

Depressurization: the stage is turned ON when the pressure is equal to or bigger than (SP2 + F10) and turned OFF when the pressure is lower than SP2.

Pressurization: the stage is turned ON when the pressure is equal to or lower than (SP2 - F10) and turned OFF when the pressure is bigger than Sp2.

F08 Minimum setpoint allowed for stage 2

Lower limit created to avoid that extremely low pressures be configured for setpoint 2

F09 Maximum setpoint allowed for stage 2

Upper limit created to avoid that extremely high pressures be configured for setpoint 2.

F10 Hysteresis for controlling stage 2

This is the difference between the pressures needed to turn stage 2 ON and OFF

F11 Stage 3 operation mode

Depressurization: the stage is turned ON when the pressure is equal to or bigger than (SP3 + F14) and turned OFF when the pressure is lower than SP3.

Pressurization: the stage is turned ON when the pressure is equal to or lower than (SP3 - F14) and turned OFF when the pressure is bigger than SP3.

2 Cyclic timer with initial state ON: Configures the output 3 as a cyclic timer with initial state ON. Function F15 must be configured as a cyclic timer or an alarm for this option to become available.

3 Cyclic timer with initial state OFF: Configures the output 3 as a cyclic timer with initial state OFF. Function F15 must be configured as a cyclic timer or an alarm for this option to become available.

4 Inside Range Limits alarm: Configures output 3 as an alarm that actuates when pressure is inside the range limits; Functions F12 and F13 indicate respectively the lower and upper pressure limits. F15 must be configured as a cyclic timer or alarm for this function to become available.

5 Out of Range Limits alarm: Configures output 3 as an alarm that actuates when pressure is out of the range limits; Functions F12 and F13 indicate respectively the lower and upper pressure limits. F15 must be configured as a cyclic timer or alarm for this function to become available.

6 Out of Setpoint 1 Range Limits alarm: Configures output 3 as an alarm that actuates when pressure is out of the setpoint 1 range limits; The actuation occurs when the pressure is lower than (SP1-F12) or higher than (SP1+F13). Function F15 must be configured as a cyclic timer or alarm for this function to become available.

F12 Minimum setpoint allowed for stage 3
Lower limit created to avoid that extremely low pressures be configured for setpoint 3.

F13 Maximum setpoint allowed for stage 3
Upper limit created to avoid that extremely high pressures be configured for setpoint 3.

F14 Hysteresis for controlling stage 3
This is the difference between the pressures needed to turn stage 3 ON and OFF

F15 Stage 4 operation mode

0 Depressurization: the stage is turned ON when the pressure is equal to or bigger than (SP4 + F18) and turned OFF when the pressure is lower than SP4. F11 must be configured with the values "0" or "1" for this option to become available.

1 Pressurization: the stage is turned ON when the pressure is equal to or lower than (SP4-F18) and turned OFF when the pressure is bigger than SP4. Function F11 must be configured with the values "0" or "1" for this function to become available.

2 Cyclic timer with initial state ON: Configures the output 4 as a cyclic timer with initial state ON.

3 Cyclic timer with initial state OFF: Configures the output 4 as a cyclic timer with initial state OFF.

4 Inside Range Limits alarm: Configures output 4 as an alarm that actuates when pressure is inside the range limits; functions F16 and F17 indicate respectively the lower and upper pressure limits. F15 must be configured as a cyclic timer or alarm for this function to become available.

5 Out of Range Limits alarm: Configures output 4 as an alarm that actuates when pressure is out of the range limits; functions F16 and F17 indicate respectively the lower and upper pressure limits.

6 Out of Setpoint 1 Range Limits alarm: Configures output 4 as an alarm that actuates when pressure is out of the setpoint 1 range limits; the actuation occurs when the pressure is lower than (SP1-F16) or higher than (SP1+F17).

F16 Minimum setpoint allowed for stage 4
Lower limit created to avoid that extremely low pressures be configured for setpoint 4.

F17 Maximum setpoint allowed for stage 4
Upper limit created to avoid that extremely high pressures be configured for setpoint 4.

F18 Hysteresis for controlling stage 4
This is the difference between the pressures needed to turn stage 4 ON and OFF

F19 Low pressure alarm
This is the pressure reference value for turning ON the indication of 'pressure below desired point'. When this alarm occurs, the stages configured for pressurization or depressurization will have their outputs turned ON or OFF according to the mode configured in F21.

F20 High pressure alarm
This is the pressure reference value for turning ON the indication of 'pressure above desired point'. When this alarm occurs, the stages configured for pressurization or depressurization will have their outputs turned ON or OFF according to the mode configured in F21.

F21 Stage action when sensor error occurs
This function defines the state for each control output when an error occurs in the pressure sensor readings or when a visual alarm situation appears (F19 or F20). Only the stages configured for pressurization or depressurization will have their status changed by this function. The amount of time set in F30, F31 and F32 remain valid when this situation occurs. The stages configured for Cyclic Timer and Alarm Output (if any) will continue performing their functions.

Function Value	Out 1	Out 2	Out 3	Out 4
0	OFF	OFF	OFF	OFF
1	ON	OFF	OFF	OFF
2	OFF	ON	OFF	OFF
3	ON	ON	OFF	OFF
4	OFF	OFF	ON	OFF
5	ON	OFF	ON	OFF
6	OFF	ON	ON	OFF
7	ON	ON	ON	OFF
8	OFF	OFF	OFF	ON
9	ON	OFF	OFF	ON
10	OFF	ON	OFF	ON
11	ON	ON	OFF	ON
12	OFF	OFF	ON	ON
13	ON	OFF	ON	ON
14	OFF	ON	ON	ON
15	ON	ON	ON	ON

F22 Alarm time ON
This function adjusts the amount of time the output(s) configured for Alarm will remain turned ON. Changing the function value to "000" causes the output to stay constantly actuated until you change it again to another value.

F23 Alarm time OFF
This function adjusts the amount of time the output(s) configured for Alarm will remain turned OFF. Changing the function value to "000" causes the output to stay constantly actuated until you change it again to another value.

F24 Alarm guard time ON
When the controller is turned ON this function inhibits the alarm during a certain period to allow the system to reach the desired pressure.

F25 Cyclic timer time ON
This is the amount of time the output(s) configured for cyclic timer will remain turned ON.

F26 Cyclic timer time OFF
This is the amount of time the output(s) configured for cyclic timer will remain turned OFF.

F27 Cyclic timer time unit
This is the time unit used in the cyclic timer functions

- 0 Seconds
- 1 Minutes

F28 Cyclic timer guard OFF
When the controller is turned ON this function inhibits the cyclic timer during a certain period of time.

F29 Controller guard time OFF
Amount of time counted from device start-up when the pressure is displayed but no alarm or stage is actuated.

F30 Minimum stage time ON
This is the minimum period of time a stage can remain turned ON. That means the period of time between the last start and the next stop. This is to avoid high voltage surges in the power supply lines.

F31 Minimum stage time OFF
This is the minimum period of time a stage can remain turned OFF. That means the period of time between the last stop and the next start.

F32 Minimum time between actuation of 2 different stages
This period ensures that no simultaneous activation of 2 or more stages will occur. This prevents overload in the power supply lines.

F33 Actuation sequence
You can select the actuation sequence for the outputs configured for pressurization or depressurization.

- 0 1 → 2 → 3 → 4
- 1 2 → 3 → 4 → 1
- 2 3 → 4 → 1 → 2
- 3 4 → 1 → 2 → 3

F34 Rotative output actuation
This allows to use the option for actuating the outputs according to the amount of time they are in the current state (ON or OFF). In this mode the outputs are commanded in the following way: the next output to be turned ON is that which sums up the shortest work time and the next output to be turned OFF is that which sums up the longest work time.

F35 Maximum operation time between services in stage 1
Maximum amount of time (in 10-hour increments) in which the stage 1 can remain working without maintenance work.

F36 Maximum operation time between services in stage 2
Maximum amount of time (in 10-hour increments) in which the stage 2 can remain working without maintenance work.

F37 Maximum operation time between services in stage 3
Maximum amount of time (in 10-hour increments) in which the stage 3 can remain working without maintenance work.

F38 Maximum operation time between services in stage 4
Maximum amount of time (in 10-hour increments) in which the stage 4 can remain working without maintenance work.

F39 Device address in the RS-485 network (serial communication)
Device address in the network for communication with SITRAD® software.
Note: it is not allowed to have more than one device with the same address in a network.

5. FUNCTIONS WITH FACILITATED ACCESS

5.1 - Viewing minimum and maximum pressure value

Press **▲** key to view the minimum and maximum pressure values set in the pressure controller. After pressing the key the minimum and maximum pressure values will be displayed followed by the message **--** which means the operation ended. If you hold the **▲** key pressed, the values are reset and the message **F5E** is displayed.

5.2 - Viewing the work time:

Press **▼** key to view the work time for each control stage. After pressing this key the message **0-** will be displayed together with the stage number. The work time is then displayed for this stage (work time = value displayed x 10). This operation repeats for the 4 controller stages until the message **--** is displayed indicating end of operation.

5.3 - Temporary disabling the alarm outputs

Pressing the **▼** and **SET** key together for 2 seconds you can temporarily disable all outputs configured for alarm until the alarm situation changes. The messages **RLP** and **OFF** are displayed indicating end of operation.

5.4 - Cyclic timer output reversion

To reverse the state of the outputs configured for cyclic timer just press the **▼** key for 2 seconds. The **-** message is displayed indicating end of operation.

5.5 - Resetting a service alarm

If a service alarm occurs, the display alternates the message **R-** with the stage number. To reset the alarm just press **▲** and **SET** keys together for 4 seconds. The stage alarm message is then displayed followed by the **F5E** message, indicating the alarm was reset. This operation will be performed automatically for every service alarm present. When the service alarm is reset the work time counter for the corresponding compressor is also reset.

6. OUTPUT ACTUATION SCHEDULE

Work time dependant Rotative Output Actuation (Function F34).

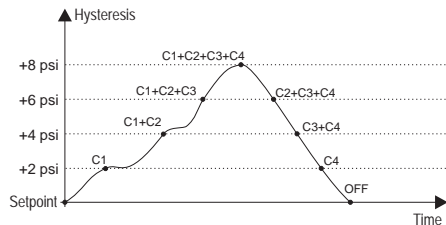

7. SIGNALLING

- AL0** Low pressure alarm
- AL1** High pressure alarm
- R-1** Output 1 service alarm
- R-2** Output 2 service alarm
- R-3** Output 3 service alarm
- R-4** Output 4 service alarm
- ERR** Pressure sensor disconnected or out of the range
- PPP** Configuration parameters not set or out of the range

8. PRESSURE MEASUREMENT UNIT SELECTION

To define the pressure measurement unit to be displayed by the controller, enter the access code '231' in the function **F01** and press the **SET** key to confirm. The display shows **UN**. Press **▼** or **▲** to choose between:

- PSI** PSI pressure unit
- BAR** Bar pressure unit

Press **SET** to confirm. The message **FRL** is displayed confirming the operation. When you change the measurement unit the function values are reset to the factory default.

9. TRANSDUCER TYPE SELECTION

To configure the type of transducer the controller will operate with, enter the access code '312' at the **F01** function and confirm it with the **SET** key. The display shows **TRN**. Press **▼** or **▲** to choose between:

- PLD** Low pressure transducer (0 to 100 psi or 0 to 6.9 bar)
- PHI** High pressure transducer (0 to 500 psi or 0 to 34.4 bar)

Press **SET** to confirm the selection. The display shows **FRL** confirming that the operation was completed. When you change the transducer type the function values are reset to the factory default.

10. WIRING DIAGRAM

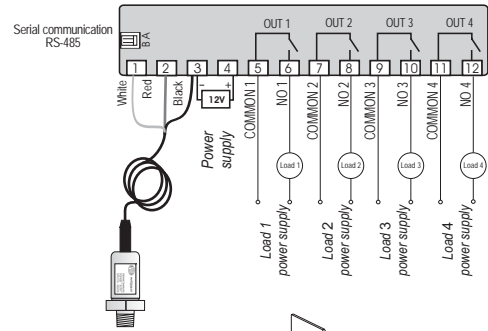

TRANSDUCER ELECTRICAL CONNECTION

Red: 5Vdc
Black: Ground
White: Output

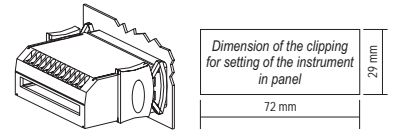

Integrating Controllers, RS-485 Serial Interface and Computer

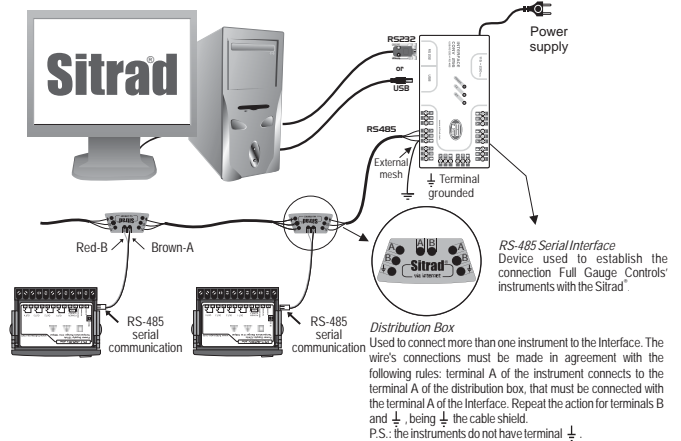

IMPORTANT

According to the chapters of norm IEC 60364:

- 1: Install protector against overvoltage on the power supply
- 2: Sensor cables and signal cables of the computer may be joined, but not in the same electric conduit through which the electric input and the activation of the loads run
- 3: Install transient suppressors (RC filters) parallel to the loads as to increase the product life of the relays.

For more information, please contact our Technical Support by e-mail: support@fullgauge.com or by phone +55 51 3475.3308

Schematic for the connection of suppressors to contactors

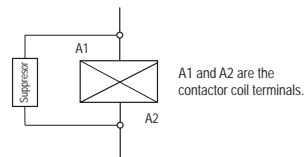

Schematic for the connection of suppressors to direct activation loads



PROTECTIVE VINYL:

This adhesive vinyl (included inside the packing) protects the instruments against water drippings, as in commercial refrigerators, for example. Do the application after finishing the electrical connections.

Remove the protective paper and apply the vinyl on the entire superior part of the device, folding the flaps as indicated by the arrows.

